

BMW-DCS-57

Heavy Duty Crane Scale

※ Dimensions:

Unit (mm)

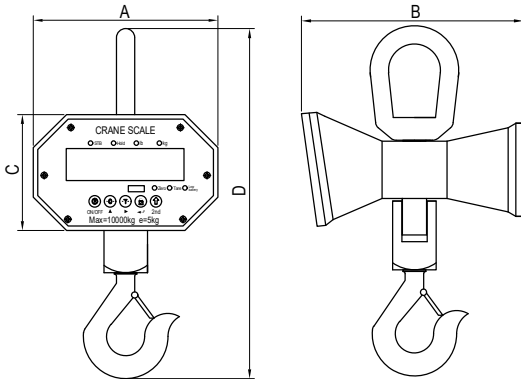

※ Technical Parameters

- ◆ Accuracy class: III
- ◆ Display: 5-digit 38mm LED or 40mm LCD with backlight
- ◆ Work environment: -10°C ~ +40°C, ≤ 85%RH
- ◆ Power supply: AC110~220V 50/60Hz, built-in DC6V/4Ah lead acid battery

※ Structural Features

- ◆ Integrated design, ensure weighing accuracy and strength
- ◆ Cast aluminum alloy housing, ensure strength
- ◆ Surface is treated with shot blasting and spray paint processing, anti-corrosion
- ◆ Hermetically sealed, waterproof structure
- ◆ Reinforced alloy steel, ensure overload performance and safety

※ Product Functions:

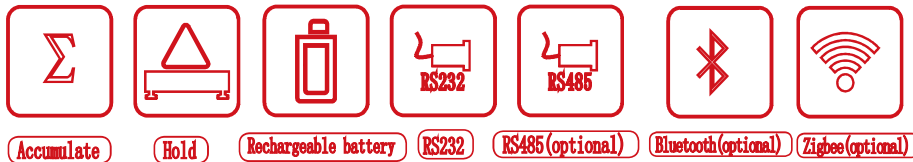

※ Types & Specifications:

Item No.	Capacity	Division (kg)	A	B	C	D	Weight (kg)	Ctn size (mm)
BMW-DCS-57-3t	3t	1/0.5	250	290	156	570	15	545*350*280
BMW-DCS-57-5t	5t	2/1	250	290	156	570	15	545*350*280

Dimensional Tolerance ±10 mm